

- GENERAL NOTES**
1. ALL DIMENSIONS ARE IN MILLIMETRES UNLESS NOTED OTHERWISE
  2. ONLY WRITTEN DIMENSIONS SHALL BE USED. NO DIMENSIONS SHALL BE SCALED FROM THE DRAWINGS
  3. ALL LEVELS ARE IN METRES AND ARE TO MALIN HEAD DATUM
  4. ALL COORDINATES ARE IN METRES AND ARE TO IRISH TRANSVERSE MERCATOR

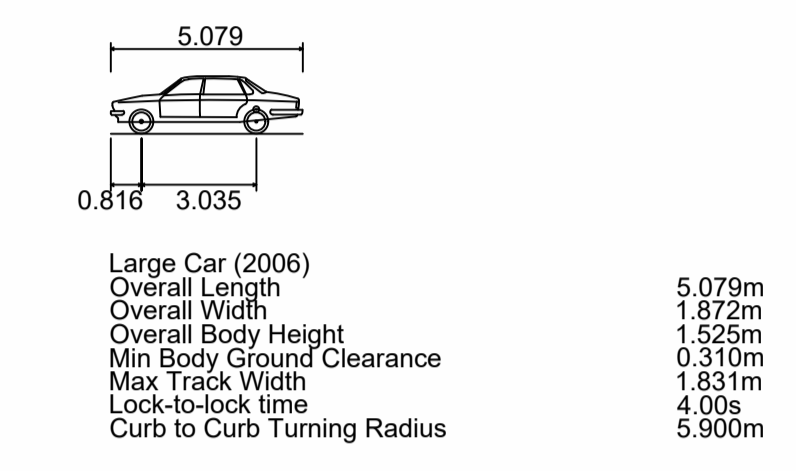

© ORDNANCE SURVEY IRELAND LICENSE No. AR 0082521  
ORDNANCE SURVEY IRELAND & GOVERNMENT OF IRELAND

<p>ATKINS Member of the SNC-Lavalin Group</p>		<p>Client SHANKILL PROPERTY INVESTMENTS LTD</p>		<p>Purpose PLANNING</p>	
<p>Project COASTAL QUARTER SHD 2</p>		<p>Title UNDER-CROFT CAR PARK BLOCK C GROUND FLOOR VEHICLE TRACKING SHEET 4 OF 5</p>		<p>Original Scale 1:200 at A1 1:400 at A3</p>	
<p>Status P</p>		<p>Drawing Number 5214419-ATK-01-ZZ-DR-CE-0124</p>		<p>Design/Drawn AK Date 19.08.22</p>	
<p>Rev P01</p>		<p>By AK</p>		<p>Checked CF</p>	
<p>Date 09.09.22</p>		<p>Date 19.08.22</p>		<p>Authorised KB</p>	
<p>Chk'd CF</p>		<p>Date 19.08.22</p>		<p>Rev P01</p>	
<p>Auth KB</p>		<p>Date 19.08.22</p>		<p>Rev P01</p>	
<p>Description ISSUED FOR PLANNING</p>		<p>Date 09.09.22</p>		<p>Rev P01</p>	
<p>By AK</p>		<p>Date 09.09.22</p>		<p>Rev P01</p>	
<p>Chk'd CF</p>		<p>Date 19.08.22</p>		<p>Rev P01</p>	
<p>Auth KB</p>		<p>Date 19.08.22</p>		<p>Rev P01</p>	